

ROHS
Compatible

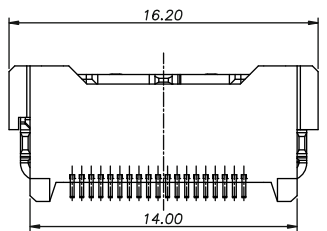
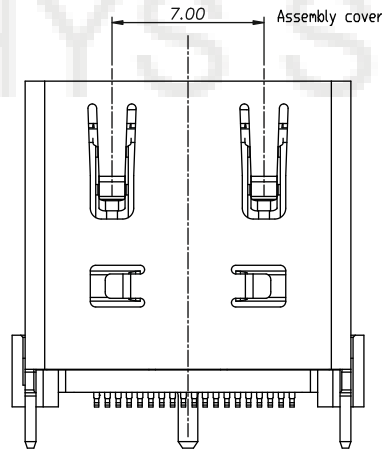
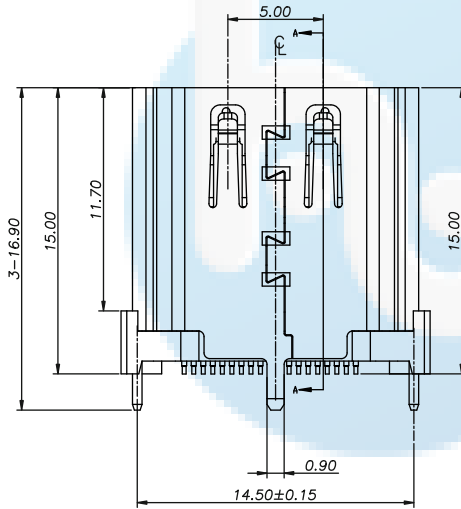
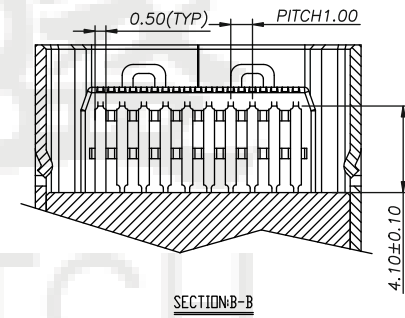
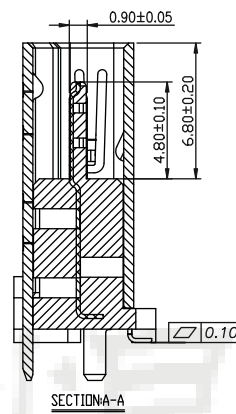
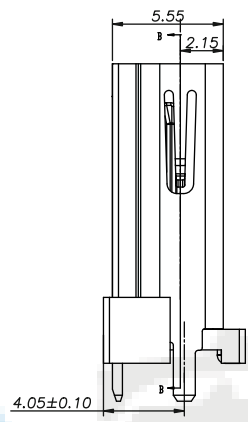
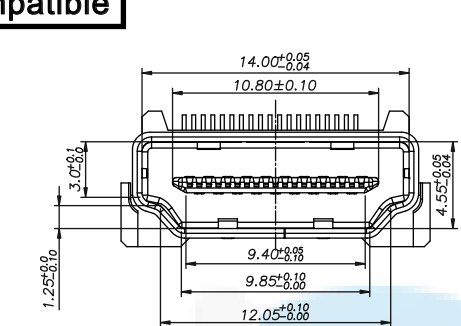

| PIN | Signal Assignment | PIN | Signal Assignment |
|-----|-------------------|-----|-------------------|
| 1 | TMDS Data2+ | 2 | TMDS Data2 Shield |
| 3 | TMDS Data2- | 4 | TMDS Data1+ |
| 5 | TMDS Data1 Shield | 6 | TMDS Data1- |
| 7 | TMDS Data0+ | 8 | TMDS Data0 Shield |
| 9 | TMDS Data0- | 10 | TMDS Clock+ |
| 11 | TMDS Clock Shield | 12 | TMDS Clock- |
| 13 | CEC | 14 | Utility |
| 15 | SCL | 16 | SDA |
| 17 | DDC/CEC Ground | 18 | +5V Power |
| 19 | Hot Plug Detect | | |

| | | | |
|----------|---------------|-------|---------------|
| DESIGN | Li Jinwei | SCALL | |
| DRAWING | Wu Qifa | UNIT | mm |
| CHECK | Zheng Jinxian | SIZE | A4: 210 * 297 |
| APPROVAL | Liu Xiaohong | DATE | 2020-06-10 |

| | |
|-----------|-----------------|
| | |
| TOLERANCE | |
| .XX | ±0.30 X.°±2° |
| .XX | ±0.20 .X.°±1° |
| .XXX | ±0.10 .XX°±0.5° |

DRAWG NO. HYSHDR01-3193K-00BR
TITLE: HDMI 立式三脚插板SMT 侧弹 15.0L



东莞市宏煜盛实业有限公司
Dongguan hongyusheng Industry Co., Ltd
TEL: 0769-81230179 <https://www.hystypec.com>

ROHS
Compatible

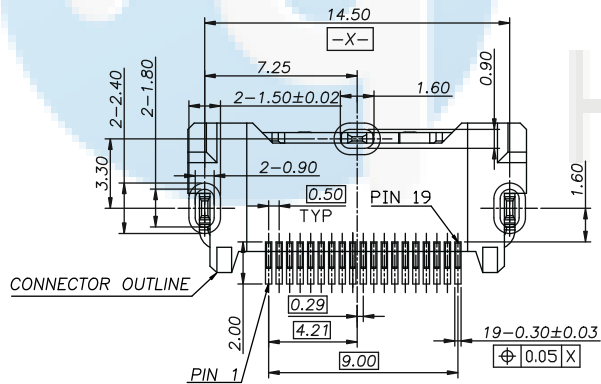
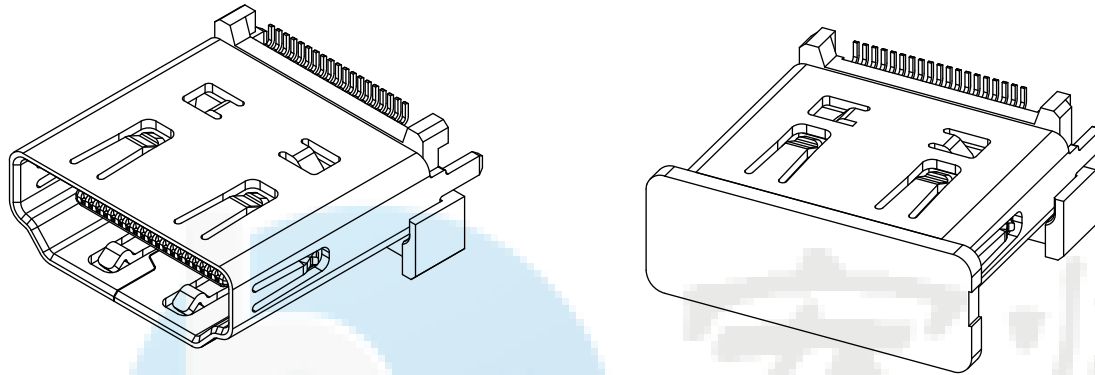

RECOMMENDED P.C.B. LAYOUT (T:1.20~1.60mm)
TOLERANCE UNSPECIFIED ±0.05mm

NOTES:

1.MATERIAL:

- 1-1 HOUSING:LCP WITH 30% G/F UL 94V-0 COLOR:BLACK.
- 1-2 CAP:LCP WITH 30% G/F UL 94V-0 COLOR:BLACK.
- 1-3 TERMINAL:COPPER ALLOY T=0.20mm
- 1-4 SHELL:SPCC/COPPER ALLOY T=0.50mm

2.PLATING:

- 2-1 TERMINAL:
(SEE P/N.)GOLD PLATED ON CONTACT AREA AND 100μ" MIN. MATTE-TIN ON SOLDER TAIL, WITH ENTIRE CONTACT UNDERPLATED 80μ" MIN.NICKEL.
- 2-2 SHELL:50μ" MIN. NICKEL PLATED.

3.MECHANICAL PERFORMANCE

- 3-1 INSERTION FORCE: 4.5kgf MAX
REMOVAL FORCE: 1kgf MIN; 4.0kgf MAX
DURABLITY:5000 CYCLES

4.ELECTRICAL PERFORMANCE:

- 4-1 Current Rating: 0.5A
- 4-2 Voltage Rating: 40V AC
- 4-3 CONTACT RESISTANC:INITIAL 30mΩ MAX.
AFTER TEST:Δ10 mΩ MAX
- 4-4 DIELECTRIC STRENGTH:UNMATED CONNECTORS APPLY 500V AC
MATED CONNECTOR APPLY 300V AC
- 4-5 INSULATION RESISTANCE:100 MEGAOHMS MIN.(UNMATED)
10 MEGAOHM'S MIN.(MATED)

5.ENVIRONMENTAL PERFORMANCE:

- OPERATING TEMPERATURE: -25°C~+85°C
- SALT SPRAY:24H

6. P/N. HDR01-3193X-10BR

- 1: GOLD FLASH PLATING ON CONTACT AREA ,
MATTE TIN 100u" Min ON SOLDER AREA
- 3: 3u" GOLD PLATING ON CONTACT AREA ,
MATTE TIN 100u" Min ON SOLDER AREA

| | | | |
|----------|---------------|-------|---------------|
| DESIGN | Li Jinwei | SCALL | |
| DRAWING | Wu Qifa | UNIT | mm |
| CHECK | Zheng Jinxian | SIZE | A4: 210 * 297 |
| APPROVAL | Liu Xiaohong | DATE | 2020-06-10 |

| | |
|-----------|-------------------------|
| DRAWG NO. | HYSHDR01-3193K-00BR |
| TITLE: | HDMI 立式三脚插板SMT 侧弹 15.0L |



东莞市宏煜盛实业有限公司
Dongguan hongyusheng Industry Co., Ltd
TEL: 0769-81230179 <https://www.hystypec.com>

ROHS
Compatible

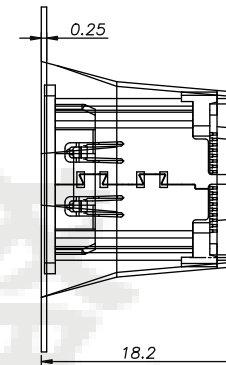
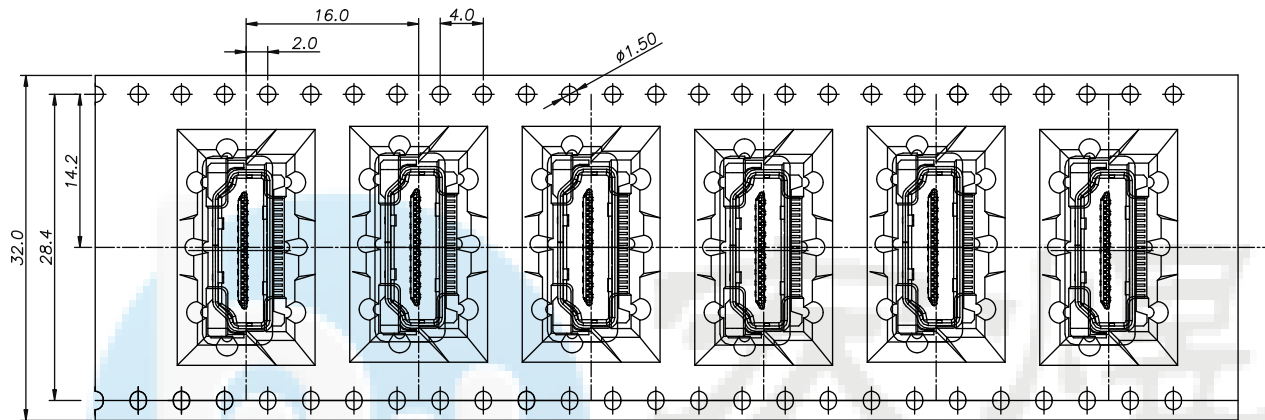

NO. 1

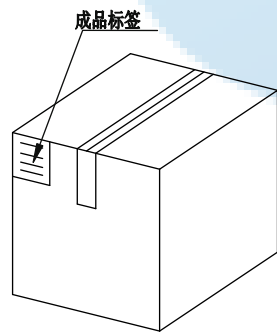

纸箱规格: 39.5*39.5*38cm

NO. 4

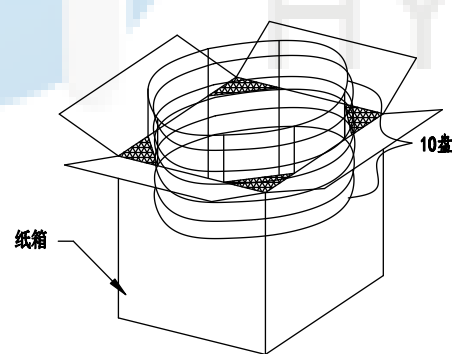

NO. 3

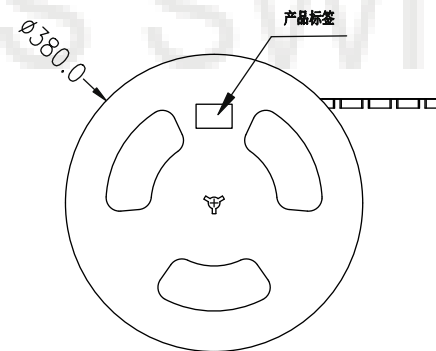

NO. 2

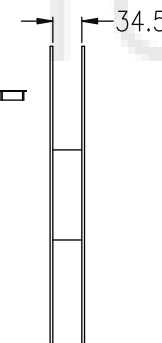

1. 包装要求:

- 1.1 每卷包装300pcs, 卷带前后各空出10pcs位置;
- 1.2 每10盘放一箱, 共计3ksets;
- 1.3 纸箱外贴上标签

备注:

1. 若有未装满之零数, 必须用泡棉塞满。
2. 针对于包装方式可根据客户要求包装。

| | | | | |
|----------|---------------|-------|---------------|--------------------------------------------------------------------------------------------------------------------------------------------------------------------|
| DESIGN | Li Jinwei | SCALL | | TOLERANCE X.X ± 0.30 X. $^{\circ} \pm 2^{\circ}$.XX ± 0.20 .X $^{\circ} \pm 1^{\circ}$.XXX ± 0.10 .XX $^{\circ} \pm 0.5^{\circ}$ |
| DRAWING | Wu Qifa | UNIT | mm | |
| CHECK | Zheng Jinxian | SIZE | A4: 210 * 297 | |
| APPROVAL | Liu Xiaohong | DATE | 2020-06-10 | |

| | |
|-----------|-------------------------|
| DRAWG NO. | HYSHDR01-3193K-00BR |
| TITLE: | HDMI 立式三脚插板SMT 侧弹 15.0L |



东莞市宏煜盛实业有限公司
Dongguan hongyusheng Industry Co., Ltd
TEL: 0769-81230179 <https://www.hystypec.com>