

ROHS
Compatible

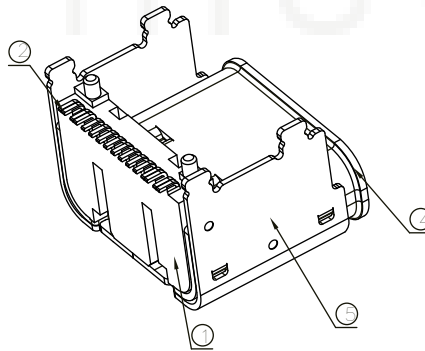
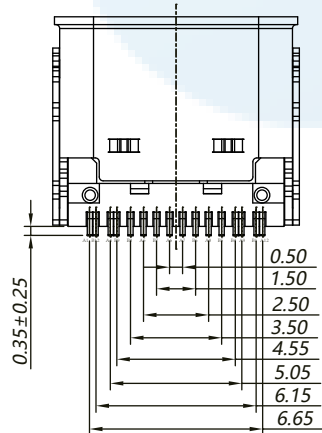
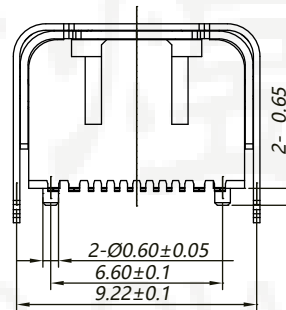
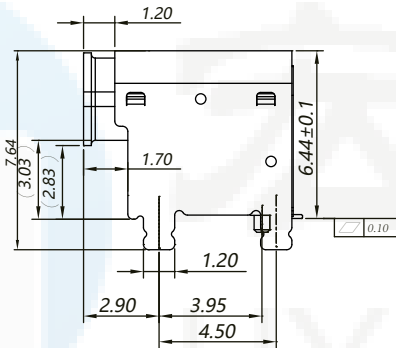
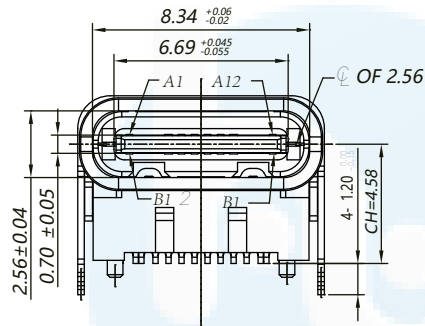
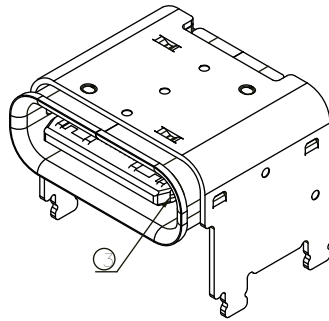
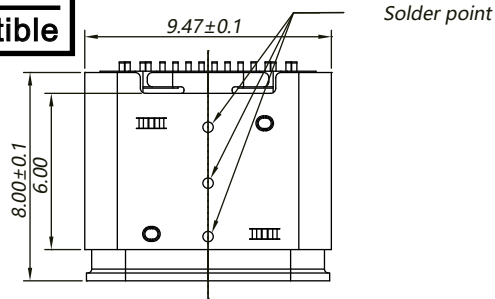

NOTE:

1. MATERIAL SPECIFICATION:
 1. HOUSING: HIGH TEMPERATURE RESISTANT PLASTIC, UL94 V-0.
 2. CONTACTS: COPPER ALLOY
 3. MID PLATE: STAINLESS STEEL
 4. INSIDE SHELL: STAINLESS STEEL
 5. OUTSIDE SHELL: STAINLESS STEEL
2. PLATING SPECIFICATION:
 - 2-1. CONTACTS:
 - Ni 50u" MIN. UNDER PLATED OVER ALL.
 - Au PLATED ON THE FUNCTIONAL AREA OF CONTACT. (GOLD PLATING THICKNESS FOLLOW THE P/N)
 - GOLD FLASH PLATING ON SOLDER AREA
 - 2-2. INSIDE SHELL OR OUTSIDE SHELL:
 - Ni 30u" MIN. UNDER PLATED OVER ALL.
3. MECHANICAL PERFORMANCE:
 - 3-1. INSERTION FORCE: 0.5~2.0kgf.
 - 3-2. REMOVAL FORCE: 0.8kgf~2.0kgf.
 - 3-3. DURABILITY: 10000 CYCLES.
4. ELECTRICAL PERFORMANCE:
 - 4-1. CURRENT RATING: 5A
VOLTAGE RATING: 20V
 - 4-2. INSULATION RESISTANCE: 100MΩ MIN
 - 4-3. DIELECTRIC WITHSTAND VOLTAGE, AC 100V FOR 1 MINUTE.
 - 4-4. LOW CONTACT RESISTANCE: INITIAL 40MΩ
AFTER 50MΩ
5. ENVIRONMENTAL PERFORMANCE:
 - OPERATING TEMPERATURE: -30°C~+80°C.
6. IR REFLOW:
 - THE PEAK TEMPERATURE ON THE BOARD SHALL BE MAINTAINED FOR 10 SECONDS AT 260°C.

5	OUTER SHELL	SUS304 T=0.25MM	NI 40u"MIN	1PCS
4	INNER SHELL	SUS304 T=0.30MM	NI 40u"MIN	1PCS
3	SHIELDING PLATE	SUS301 T=0.15MM	N/A	1PCS
2	CONTACT	C2680 T=0.15MM	Mating area 1u"Au Solder Tails:G/F Underplate:80u"Min Ni overall	2SET
1	INSERT MOLDING	LCP UL94V-0	BLACK	1PCS
NO.	DESCRIPTION	MATERIAL	REMARKS	

DESIGN	Li Jinwei	SC ALL	
DRAWING	Wu Qifa	UNIT	mm
CHECK	Zheng Jinxian	SIZE	A4: 210 * 297
APPROVAL	Liu Xiaohong	DATE	2020-06-10

TOLERANCE	
X.X ±0.30	X.°±2°
.XX ±0.20	.X°±1°
.XXX ±0.10	.XX°±0.5°

DRAWG NO.	TYPE-C-DSG16PZQ303
TITLE:	16P 板上四脚插板垫高3.3 CH=4.58 8.0L



东莞市宏煜盛实业有限公司
Dongguan hongyusheng Industry Co., Ltd
TEL: 0769-81230179 <https://www.hystypec.com>

ROHS
Compatible

USB TYPE-C PIN ASSIGNMENTS

PIN NUMBER	SIGNAL NAME	PIN NUMBER	SIGNAL NAME
A1	GND	B12	GND
A4	VBUS	B9	VBUS
A5	CC1	B8	SBU2
A6	Dp1	B7	Dn2
A7	Dn1	B6	Dp2
A8	SBU1	B5	CC2
A9	VBUS	B4	VBUS
A12	GND	B1	GND

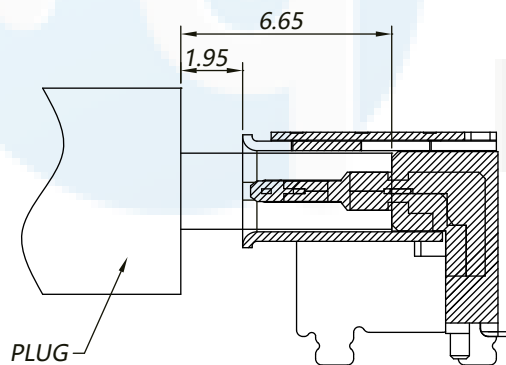

AFTER MATING
SCALE 1:1

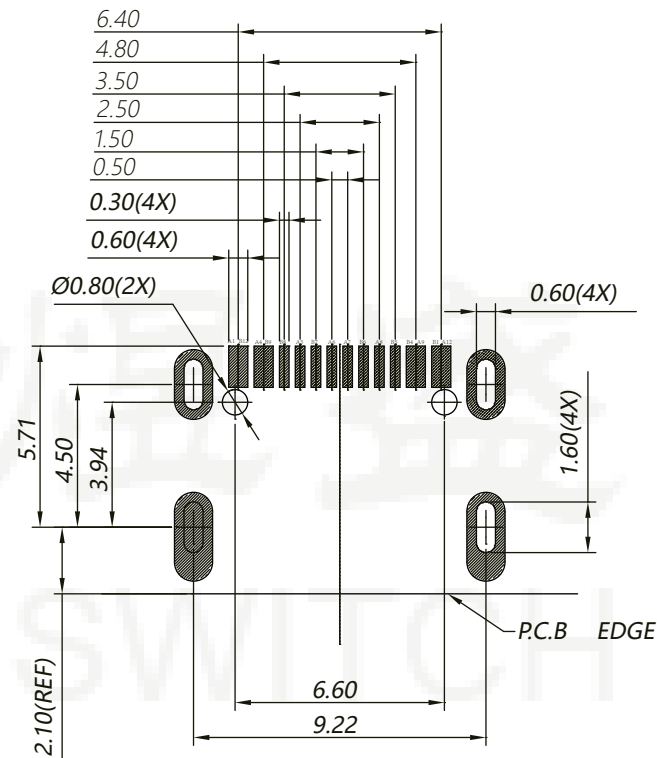

RECOMMEND P.C.B LAYOUT(COMPONENT SIDE)
TOLERANCE FOR PCB LAYOUT IS ± 0.05

DESIGN	Li Jinwei	SC ALL		 TOLERANCE X.X ± 0.30 X. $^{\circ} \pm 2^{\circ}$.XX ± 0.20 .X $^{\circ} \pm 1^{\circ}$.XXX ± 0.10 .XX $^{\circ} \pm 0.5^{\circ}$	DRAWG NO.	TYPE-C-DSG16PZQ303
DRAWING	Wu Qifa	UNIT	mm		TITLE:	16P 板上四脚插板垫高3.3 CH=4.58 8.0L
CHECK	Zheng Jinxian	SIZE	A4: 210 * 297			
APPROVAL	Liu Xiaohong	DATE	2020-06-10			



东莞市宏煜盛实业有限公司
Dongguan hongyusheng Industry Co., Ltd
TEL: 0769-81230179 <https://www.hystypec.com>

ROHS
Compatible

出料方向
PULL OUT DIRECTEON

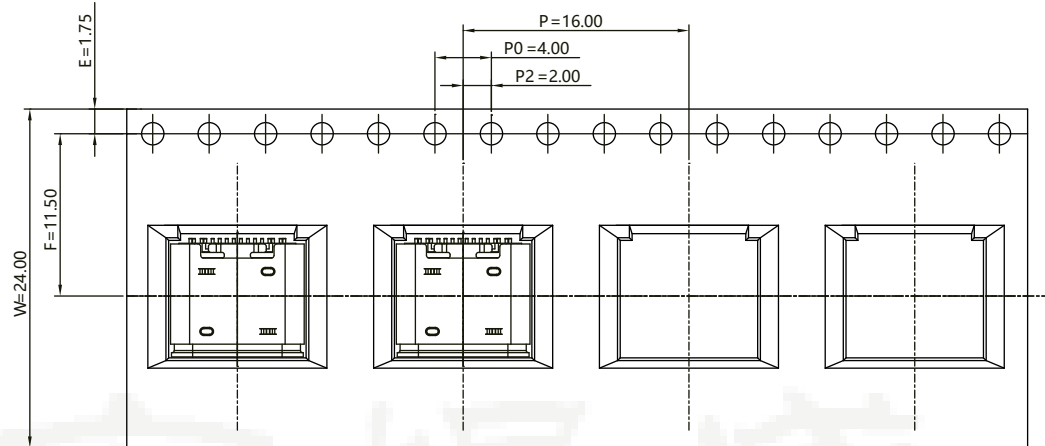
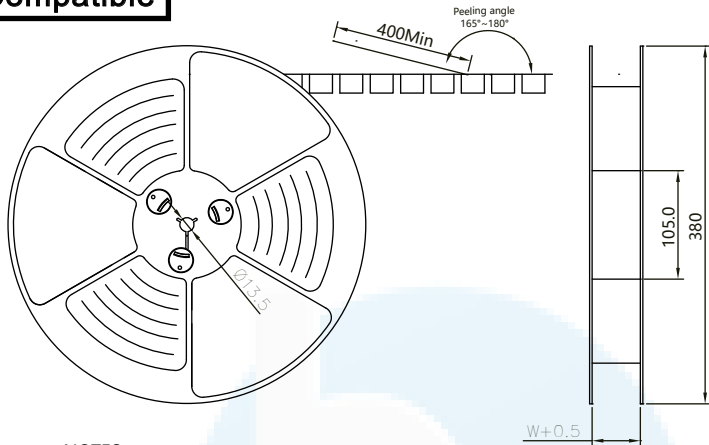

NOTES

1. 帶子引導長度
LEAD TAPE LENGTH
出料方向
PULL OUT DIRECTEON

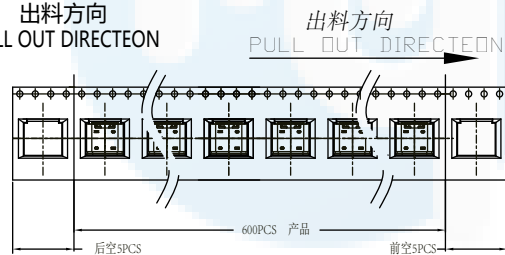

2. 上帶 剥离力為: 0.1~1.8N(10.2gf~130gf)
PEELING OFF FORCE OF TOP TAPE:0.1~1.3N(10.2gf~130gf)
出貨運輸過程中一定注意:
THIS REQUIREMENT SHOULD BE APPLIED AT SHIPMENT
卷帶在運輸過程中不能散開
PEELING OFF SHOULD NOT BE ALLOWED DURING TRANSPORTATION

TAPE & REEL 7 PCS

1 REEL
= 600 PCS

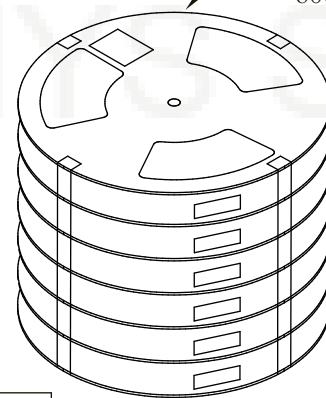

BOX

DIMENSIONS:
39.5X39.5X20

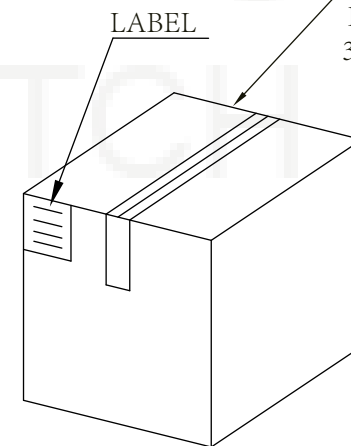

1 CARTON
=6 REELS
=3600 PCS

包装明细表 (The detail of the packing)		Carton				
产品料号 (Product No.)	包装容量 (Packing Capacity)			重量 Weight (Kg)		
	pcs/box	boxs/Carton	Pcs/Box	N.W./Pcs	N.W./Box	G.W./Box
TYPE-C-DSG16PZQ303	600	6	3600	----	----	----

DESIGN	Li Jinwei	SC ALL		 TOLERANCE X.X ±0.30 X.°±2° .XX ±0.20 .X°±1° .XXX ±0.10 .XX°±0.5°
DRAWING	Wu Qifa	UNIT	mm	
CHECK	Zheng Jinxian	SIZE	A4: 210 * 297	
APPROVAL	Liu Xiaohong	DATE	2020-06-10	

DRAWG NO.
TYPE-C-DSG16PZQ303
TITLE:
16P 板上四脚插板垫高3.3 CH=4.58 8.0L



东莞市宏煜盛实业有限公司
Dongguan hongyusheng Industry Co., Ltd
TEL: 0769-81230179 <https://www.hystypec.com>