

ROHS
Compatible

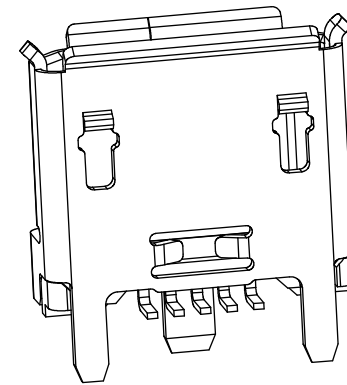

- NOTE:
- MATERIAL SPECIFICATION:
 - HOUSING: LCP,UL94 V-0 BLACK.
 - CONTACTS: BRASS (C2680)
 - FRONT SHELL: STAINLESS STEEL (SUS304)
 - PLATING SPECIFICATION:
 - CONTACTS:
 - Ni 50u" MIN. UNDER PLATED OVER ALL.
 - Au 1u"MIN PLATED ON THE FUNCTIONAL AREA OF CONTACT.
 - Au 1u"MIN PLATED ON SOLDER AREA.
 - FRONT SHELL:
 - Ni 30u" MIN. UNDER PLATED OVER ALL.
 - MECHANICAL PERFORMANCE,
 - INSERTION FORCE: 3.5kgf MAX
 - REMOVAL FORCE: 0.8kgf MIN
 - DURABILITY: 10000 CYCLES.
 - ELECTRICAL PERFORMANCE,
 - CURRENT RATING:
 - VBUS & GND PINS: 1.8A MAX.
 - OTHER PINS: 0.5A MAX.
 - LLCR:
 - VBUS & GND PINS AND OTHER PINS: 30mΩ/PIN MAX.
 - SHIELD: 50mΩ/MAX.
 - LLCR MAX. CHANGE OF ALL PINS: 10mΩ.
 - INSULATION RESISTANCE: 100MΩ MIN
 - DIELECTRIC WITHSTAND VOLTAGE,AC 100V FOR 1 MINUTE.
 - ENVIRONMENTAL PERFORMANCE:
 - OPERATING TEMPERATURE: -25°C~+85°C.
 - IR REFLOW:
 - THE PEAK TEMPERATURE ON THE BOARD SHALL BE MAINTAINED FOR 10 SECONDS AT 260°C.

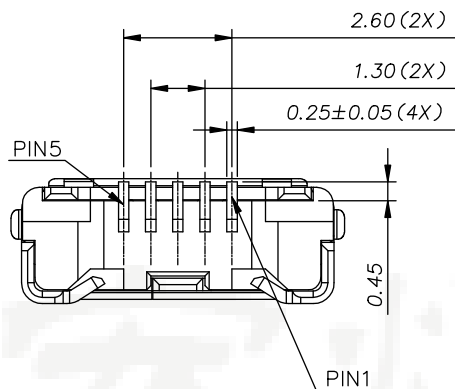
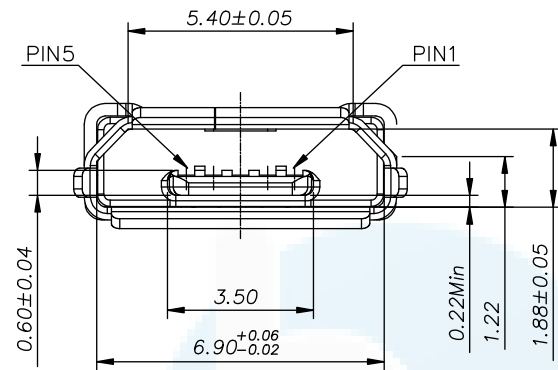
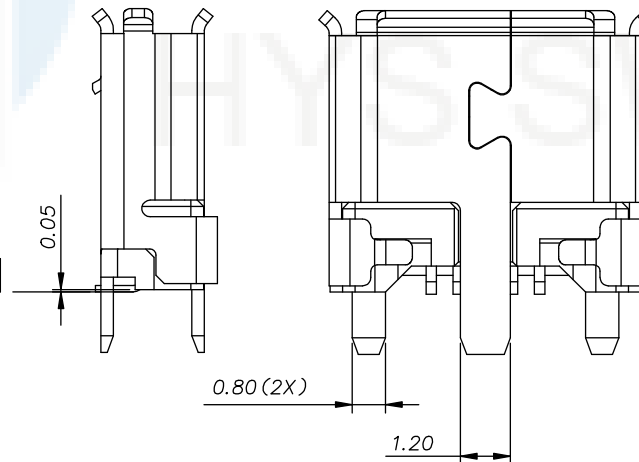
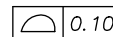
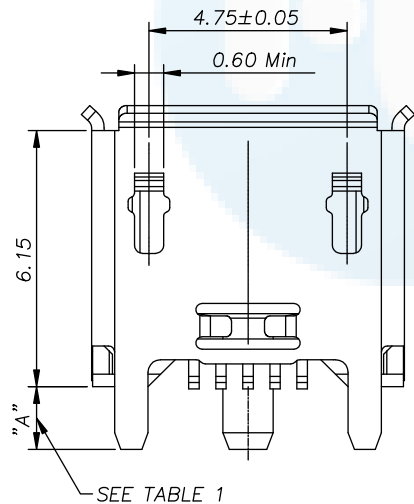

DESIGN	Li Jinwei	SCALL		 TOLERANCE X.X ±0.30 X.°±2° .XX ±0.20 .X°±1° .XXX ±0.10 .XX°±0.5°
DRAWING	Wu Qifa	UNIT	mm	
CHECK	Zheng Jinxian	SIZE	A4: 210 * 297	
APPROVAL	Liu Xiaohong	DATE	2020-06-10	

DRAWG NO.	USB-M-LDS59Q
TITLE:	5P 直立式贴片 3支脚有翻边



东莞市宏煜盛实业有限公司
Dongguan hongyusheng Industry Co., Ltd
TEL: 0769-81230179 <https://www.hystypec.com>

ROHS
Compatible

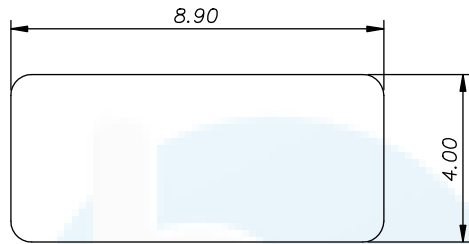

WITH PICK UP COVER

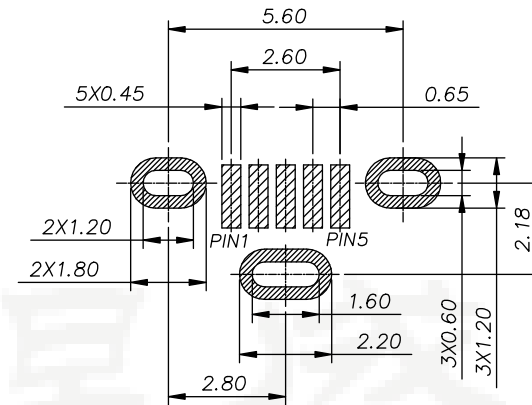
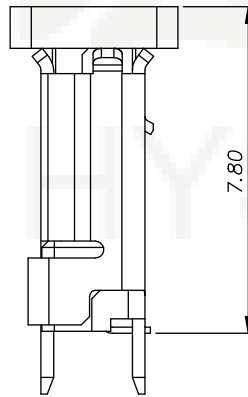
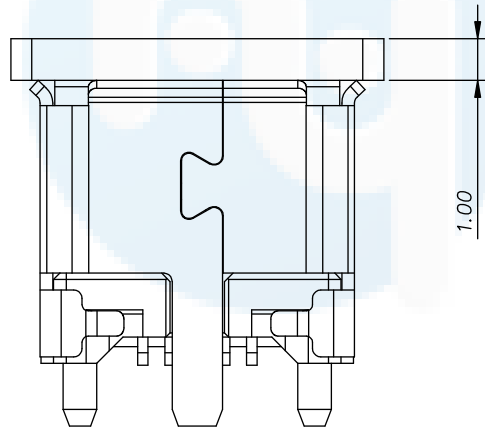

RECOMMENDED PCB LAYOUT (TOP VIEW)

DEFAULT TOLERANCE: ± 0.05

MICRO USB PIN ASSIGNMENTS

PIN NUMBER	SIGNAL NAME
Pin 1	VBUS
Pin 2	D-
Pin 3	D+
Pin 4	ID
Pin 5	GND

DESIGN	Li Jinwei	SCALL		 TOLERANCE X.X ± 0.30 X. $^{\circ} \pm 2^{\circ}$.XX ± 0.20 .X. $^{\circ} \pm 1^{\circ}$.XXX ± 0.10 .XX. $^{\circ} \pm 0.5^{\circ}$
DRAWING	Wu Qifa	UNIT	mm	
CHECK	Zheng Jinxian	SIZE	A4: 210 * 297	
APPROVAL	Liu Xiaohong	DATE	2020-06-10	

DRAWG NO.	USB-M-LDS59Q
TITLE:	5P 直立式贴片 3支脚有翻边



东莞市宏煜盛实业有限公司
Dongguan hongyusheng Industry Co., Ltd
TEL: 0769-81230179 <https://www.hystypec.com>