

ROHS
Compatible

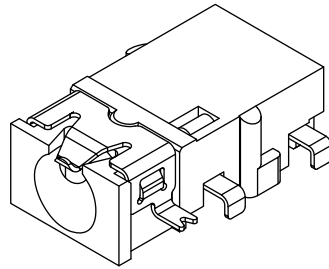

3D VIEW

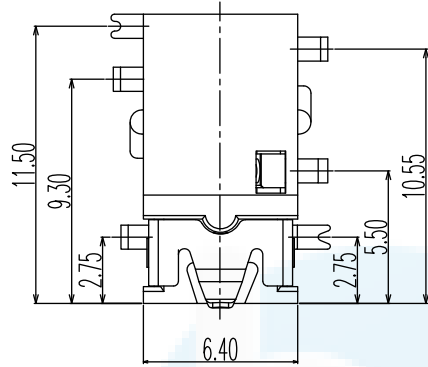
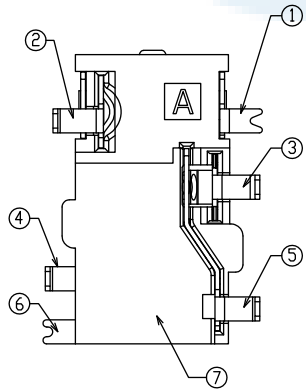
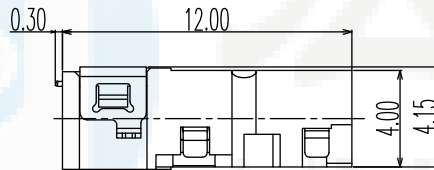
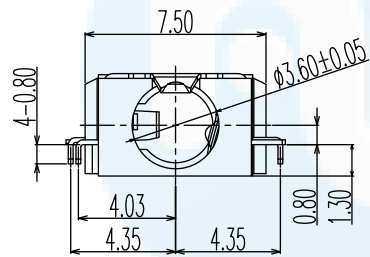

NOTES:

- CONTACT CURRENT RATING: 1A.
- CONTACT RESISTANCE: 150 mΩ MAX.;
- INSULATION RESISTANCE: 1000MΩ MIN.;
- DIELECTRIC WITHSTANDING: 500V AC MIN.;
- DURABILITY: 5,000 CYCLES MIN.;
- CONNECTOR MATING FORCES: 30N MAX.;
- CONNECTOR UNMATING FORCES: 3N MIN.;

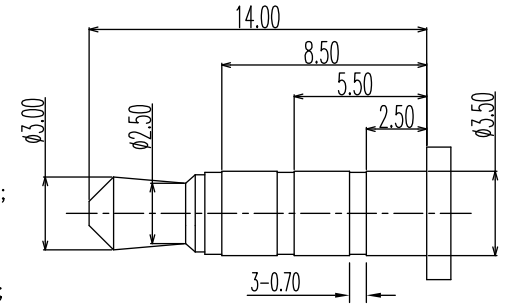

(ø3.50mm 4 POLE PLUG DETAIL DRAWING)

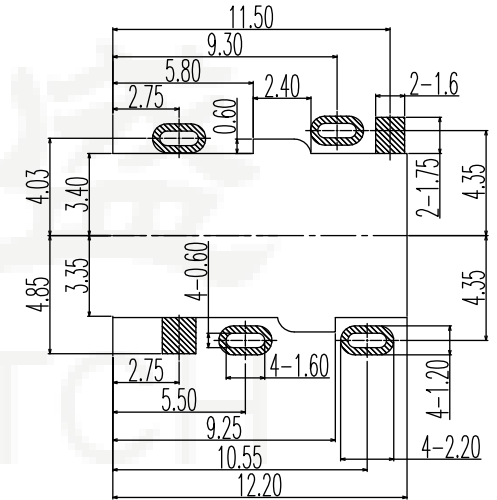
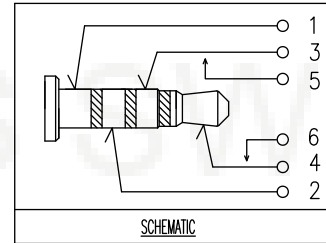
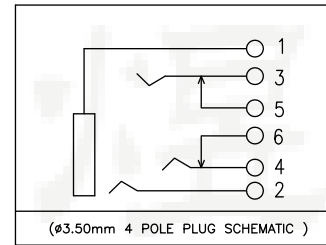

P.C.B LAYOUT
TOP VIEW

⑦	HOUSING	1	HIGH TEMPERATURE;COLOR BLACK	
⑥	CONTACT 6#	1	STAINLESS STEEL; NICKEL UNDER PLATING OVERALL,GOLD FLASH ON SOLDER AREA	T=0.2
⑤	CONTACT 5#	1	STAINLESS STEEL; NICKEL UNDER PLATING OVERALL,GOLD FLASH ON SOLDER AREA	T=0.2
④	CONTACT 4#	1	PHOSPHOR BRONZE; NICKEL UNDER PLATING OVERALL,GOLD FLASH PLATING ON SOLDER AREA ;GOLD FLASH PLATING ON CONTACT AREA	T=0.2
③	CONTACT 3#	1	STAINLESS STEEL; NICKEL UNDER PLATING OVERALL,GOLD FLASH PLATING ON SOLDER AREA ;GOLD FLASH PLATING ON CONTACT AREA	T=0.2
②	CONTACT 2#	1	PHOSPHOR BRONZE; NICKEL UNDER PLATING OVERALL,GOLD FLASH PLATING ON SOLDER AREA ;GOLD FLASH PLATING ON CONTACT AREA	T=0.2
①	CONTACT 1#	1	STAINLESS STEEL; NICKEL UNDER PLATING OVERALL,GOLD FLASH ON OVERALL;	T=0.2
ITEM	PART NAME	Q'TY	MATERIAL	REMARK

DESIGN	Li Jinwei	SCALL	
DRAWING	Wu Qifa	UNIT	mm
CHECK	Zheng Jinxian	SIZE	A4: 210 * 297
APPROVAL	Liu Xiaohong	DATE	2020-06-10

TOLERANCE	
X.X ±0.30	X.°±2°
.XX ±0.20	.X°±1°
.XXX ±0.10	.XX°±0.5°

DRAWG NO.	PJ-415
TITLE:	ø3.5mm 耳机插座

 **东莞市宏煜盛实业有限公司**
Dongguan hongyusheng Industry Co., Ltd
TEL: 0769-81230179 <https://www.hystypec.com>