

ROHS
Compatible

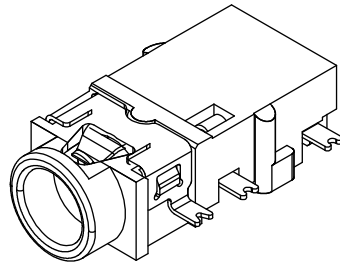
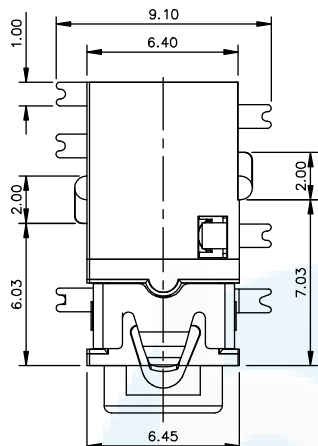

3D VIEW

NOIES.

1. REQUEST OF THE SPECIFICATION:

- 1.1 CONTACT CURRENT RATING: 1A;
- 1.2 CONTACT RESISTANCE: 100 mΩ MAX.;
- 1.3 INSULATION RESISTANCE: 100MΩ MIN.;
- 1.4 DIELECTRIC WITHSTANDING: 500V AC MIN.;
- 1.5 DURABILITY: 5,000 CYCLES MIN.;
- 1.6 CONNECTOR MATING FORCES: 29.8N (3.00Kgf) MAX.;
- 1.7 CONNECTOR UNMATING FORCES: 2.98N (0.30Kgf) MIN.;

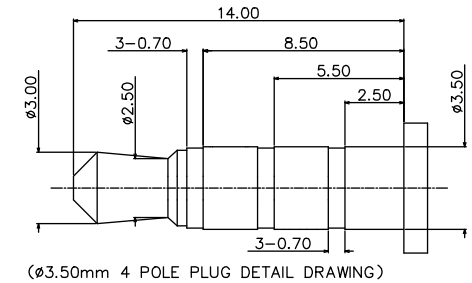

(ø3.50mm 4 POLE PLUG DETAIL DRAWING)

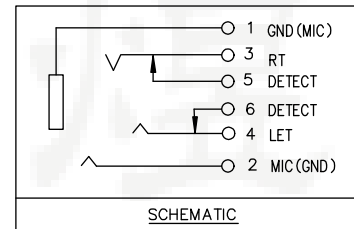
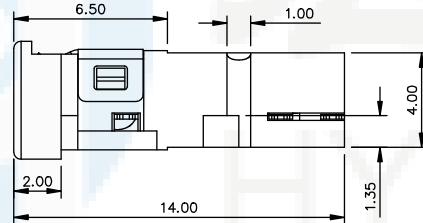
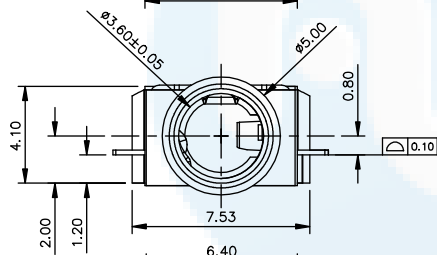

SCHEMATIC

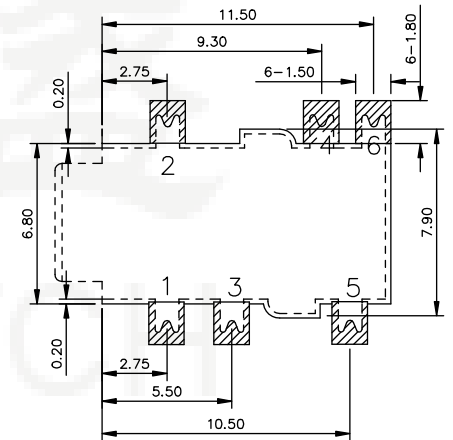

P.C.B LAYOUT
TOP VIEW

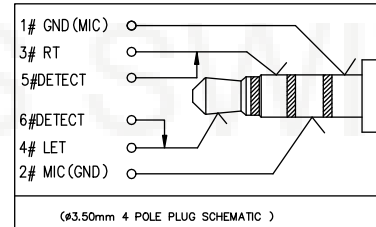

(ø3.50mm 4 POLE PLUG SCHEMATIC)

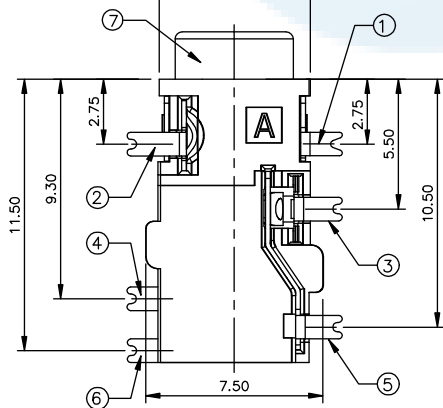

ITEM	NAME	Q'TY	DESCRIPTION	NOTE
7	HOUSING	1	PPA COLOR BLACK	
6	TERMINAL 6#	1	SUS304; NICKEL UNDER PLATING OVERALL,GOLD PLATING ON SOLDER AREA ;GOLD PLATING ON CONTACT AREA	T=0.20
5	TERMINAL 5#	1	SUS304; NICKEL UNDER PLATING OVERALL,GOLD PLATING ON SOLDER AREA ;GOLD PLATING ON CONTACT AREA	T=0.20
4	TERMINAL 4#	1	SUS304; NICKEL UNDER PLATING OVERALL,GOLD PLATING ON SOLDER AREA ;GOLD PLATING ON CONTACT AREA	T=0.20
3	TERMINAL 3#	1	SUS304; NICKEL UNDER PLATING OVERALL,GOLD PLATING ON SOLDER AREA ;GOLD PLATING ON CONTACT AREA	T=0.20
2	TERMINAL 2#	1	PHOSPHOR BRONZE; NICKEL UNDER PLATING OVERALL,GOLD PLATING ON SOLDER AREA ;GOLD PLATING ON CONTACT AREA	T=0.20
1	TERMINAL 1#	1	SUS304; NICKEL UNDER PLATING OVERALL,GOLD PLATING ON SOLDER AREA ;GOLD PLATING ON CONTACT AREA	T=0.20

DESIGN	Li Jinwei	SCALL	
DRAWING	Wu Qifa	UNIT	mm
CHECK	Zheng Jinxian	SIZE	A4: 210 * 297
APPROVAL	Liu Xiaohong	DATE	2020-06-10

TOLERANCE	
X.X ±0.30	X.°±2°
.XX ±0.20	.X°±1°
.XXX ±0.10	.XX°±0.5°

DRAWG NO.	PJ-418
TITLE:	Φ3.5mm耳机插座

东莞市宏煜盛实业有限公司
Dongguan hongyusheng Industry Co., Ltd
TEL: 0769-81230179 <https://www.hystypec.com>