

**ROHS**  
Compatible

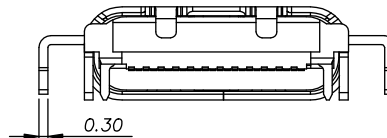
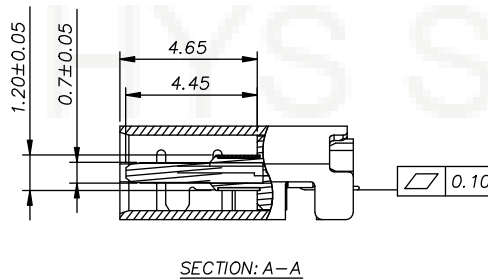
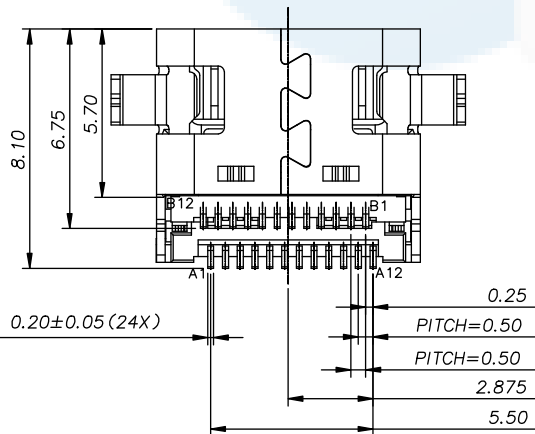
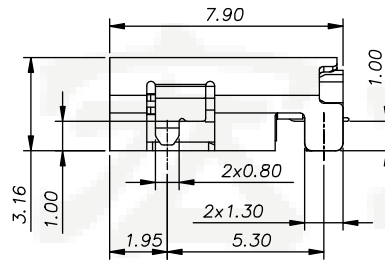
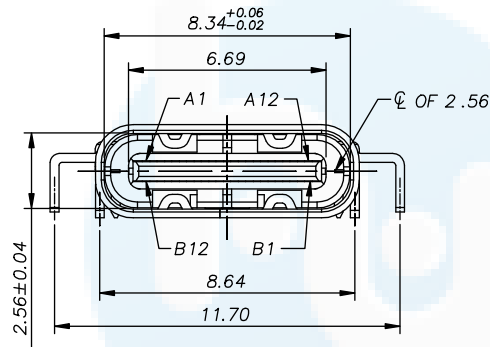
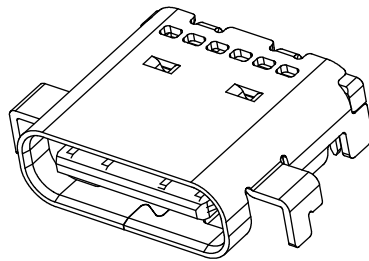
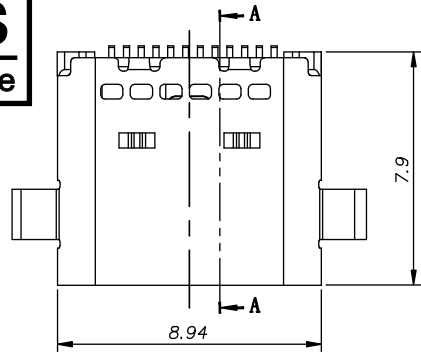

**NOTE:**

**1.MATERIAL SPECIFICATION:**

- 1.HOUSING: HIGH TEMPERATURE RESISTANT PLASTIC, UL94 V-0.
- 2.CONTACTS: COPPER ALLOY
- 3.MID PLATE: STAINLESS STEEL
- 4.FRONT SHELL: STAINLESS STEEL
- 5.EMI PLATE: STAINLESS STEEL

**2.PLATING SPECIFICATION:**

**2-1.CONTACTS:**

Ni 50u" MIN. UNDER PLATED OVER ALL.

Au PLATED ON THE FUNCTIONAL AREA OF CONTACT.

(GOLD PLATING THICKNESS FOLLOW THE P/N)

PLATING SPECIFICATIONS OF THE SOLDER AREA FOLLOW THE P/N

**2-2.FRONT SHELL:**

Ni 30u" MIN. UNDER PLATED OVER ALL.

**2-3.MID PLATE&EMI PLATE:**

CLEAR ONLY

**3.MECHANICAL PERFORMANCE,**

3-1.INSERTION FORCE: 0.5~2.0kgf.

3-2.REMOVAL FORCE: 0.8kgf~2.0kgf.

3-3.DURABILITY: 10000 CYCLES.

**4.ELECTRICAL PERFORMANCE,**

4-1. CURRENT RATING: 5.0A

VOLTAGE RATING: 5.0V

**4-2. LLCR:**

VBUS & GND PINS AND OTHER PINS: 40mΩ/PIN MAX.

SHIELD: 50mΩ/MAX.

LLCR MAX. CHANGE OF ALL PINS: 10mΩ

4-3.INSULATION RESISTANCE: 100MΩ MIN

4-4.DIELECTRIC WITHSTAND VOLTAGE, AC 100V FOR 1 MINUTE.

**5. ENVIRONMENTAL PERFORMANCE:**

OPERATING TEMPERATURE: -25°C~+85°C.

**6.IR REFLOW:**

THE PEAK TEMPERATURE ON THE BOARD SHALL BE MAINTAINED FOR 10 SECONDS AT 260°C.

DESIGN	Li Jinwei	SCALL	
DRAWING	Wu Qifa	UNIT	mm
CHECK	Zheng Jinxian	SIZE	A4: 210 * 297
APPROVAL	Liu Xiaohong	DATE	2020-06-10

TOLERANCE	
.XX ±0.30	.X.°±2°
.XX ±0.20	.X.°±1°
.XXX ±0.10	.XX°±0.5°

DRAWG NO.	TYPE-C-CDS24P100
TITLE:	24P沉板1.0四脚插板SMT7.9L

**东莞市宏煜盛实业有限公司**

**Dongguan hongyusheng Industry Co., Ltd**

TEL: 0769-81230179 <https://www.hystypec.com>

**ROHS**  
Compatible

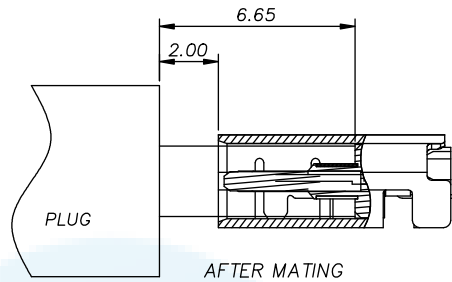

USB TYPE-C PIN ASSIGNMENTS

PIN NUMBER	SIGNAL NAME	PIN NUMBER	SIGNAL NAME
A1	GND	B12	GND
A2	SSTXp1	B11	SSRXp1
A3	SSTXn1	B10	SSRXn1
A4	VBus	B9	VBus
A5	CC1	B8	SBU2
A6	Dp1	B7	Dn2
A7	Dn1	B6	Dp2
A8	SBU1	B5	CC2
A9	VBUS	B4	VBus
A10	SSRXn2	B3	SSTXn2
A11	SSRXp2	B2	SSTXp2
A12	GND	B1	GND

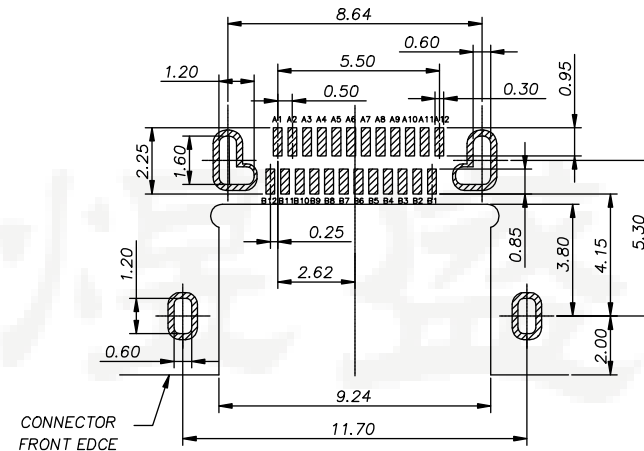

RECOMMENDED P.C.B. LAYOUT  
TOLERANCE UNSPECIFIED ±0.05mm

RECOMMENDED PCB LAYOUT (TOP VIEW)  
THICKNESS 0.60MM; DEFAULT TOLERANCE: ±0.05

DESIGN	Li Jinwei	SCALL	
DRAWING	Wu Qifa	UNIT	mm
CHECK	Zheng Jinxian	SIZE	A4: 210 * 297
APPROVAL	Liu Xiaohong	DATE	2020-06-10

TOLERANCE	
X.X ±0.30	X.°±2°
.XX ±0.20	.X°±1°
.XXX ±0.10	.XX°±0.5°

DRAWG NO.	TYPE-C-CDS24P100
TITLE:	24P沉板1.0四脚插板SMT7.9L

**东莞市宏煜盛实业有限公司**  
 Dongguan hongyusheng Industry Co., Ltd  
 TEL: 0769-81230179 <https://www.hystypec.com>

**ROHS**  
Compatible

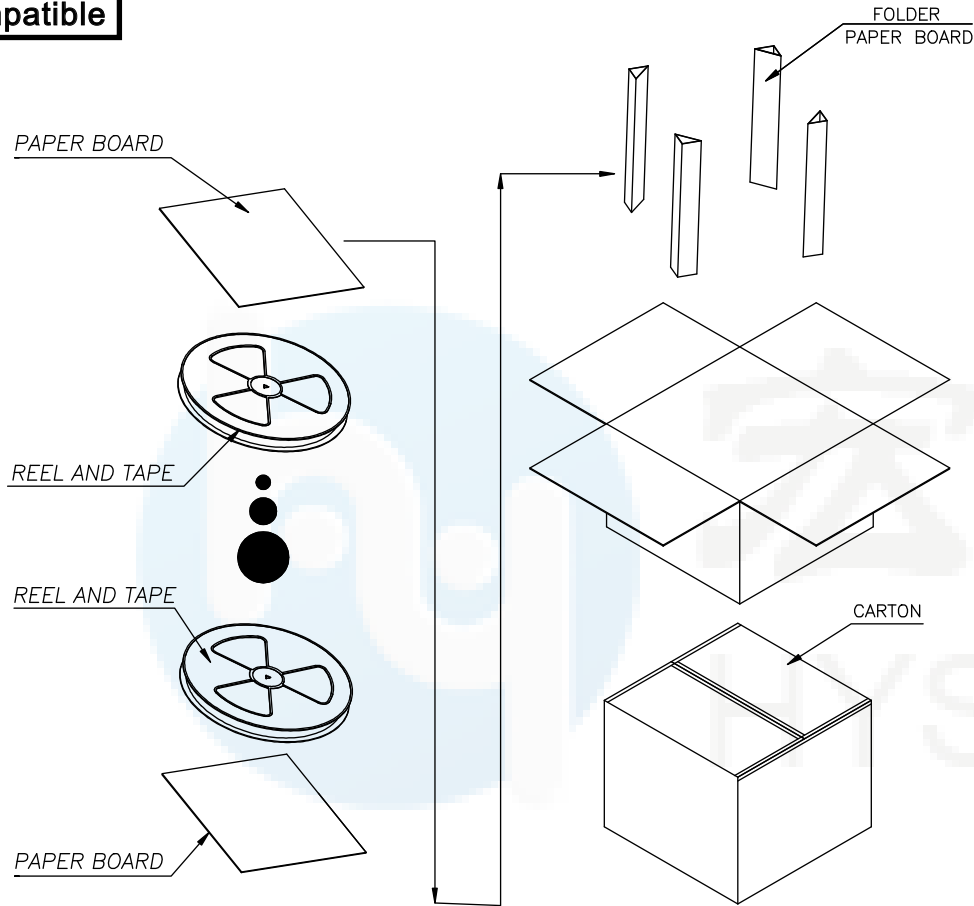

	REEL	CARTON
CONNECTOR (PCS)	1000	10000

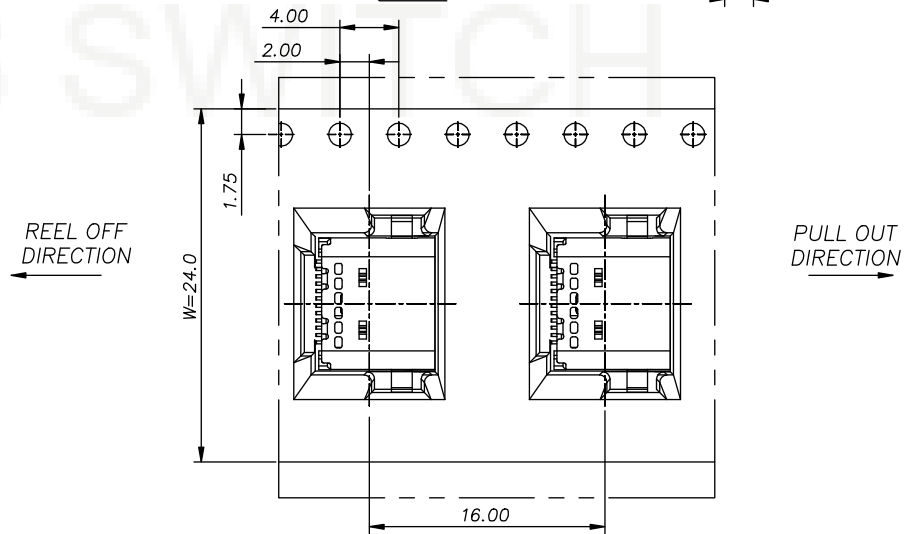
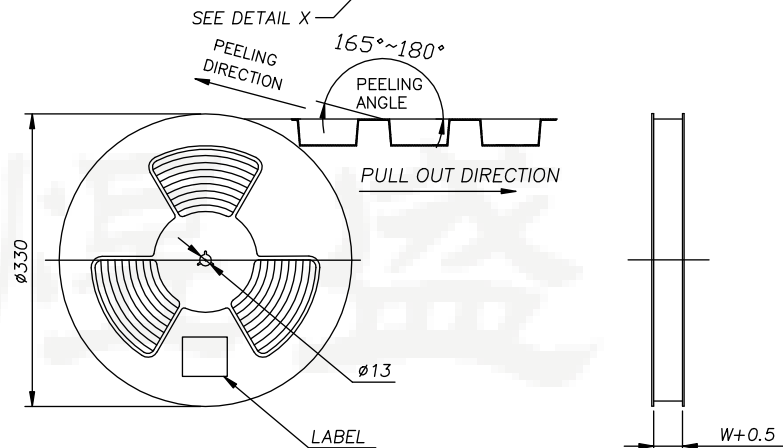
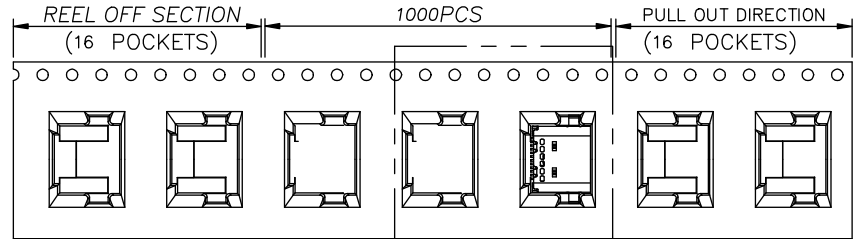

DESIGN	Li Jinwei	SCALL		 TOLERANCE X.X $\pm 0.30$ X. $^{\circ} \pm 2^{\circ}$ .XX $\pm 0.20$ .X $^{\circ} \pm 1^{\circ}$ .XXX $\pm 0.10$ .XX $^{\circ} \pm 0.5^{\circ}$
DRAWING	Wu Qifa	UNIT	mm	
CHECK	Zheng Jinxian	SIZE	A4: 210 * 297	
APPROVAL	Liu Xiaohong	DATE	2020-06-10	

DRAWG NO.	TYPE-C-CDS24P100
TITLE:	24P沉板1.0四脚插板SMT7.9L

**东莞市宏煜盛实业有限公司**  
 Dongguan hongyusheng Industry Co., Ltd  
 TEL: 0769-81230179 <https://www.hystypec.com>