

ROHS
Compatible

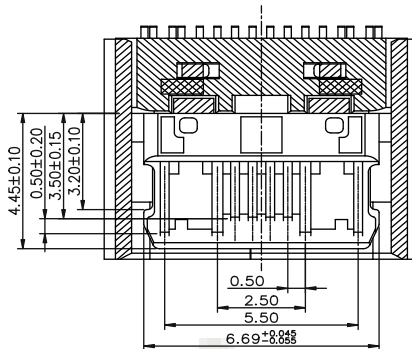

SECTION B-B
SCALE 1:1

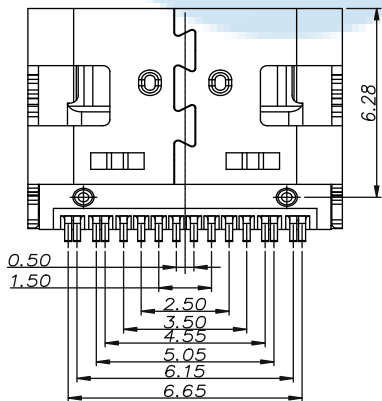
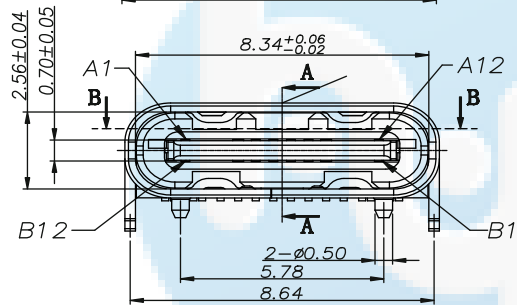
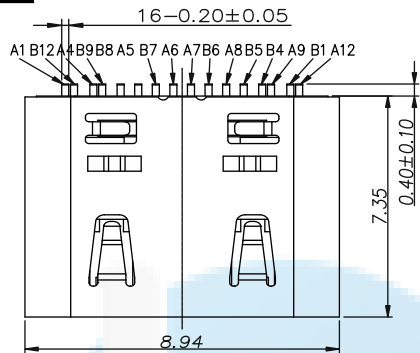
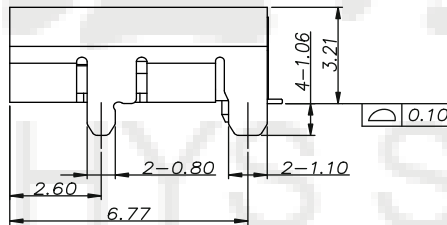

SECTION A-A
SCALE 1:1

NOTE:

- 1.MATERIAL SPECIFICATION:
 - 1.HOUSING:HIGH TEMPERATURE RESISTANT PLASTIC,UL94 V-0.
 - 2.CONTACTS: COPPER ALLOY
 - 3.MID PLATE: STAINLESS STEEL
 - 2.PLATING SPECIFICATION:
 - 2-1.CONTACTS:
 - Ni 50u" MIN. UNDER PLATED OVER ALL.
 - Au PLATED ON THE FUNCTIONAL AREA OF CONTACT.
 - (GOLD PLATING THICKNESS FOLLOW THE P/N)
 - GOLD FLASH PLATING ON SOLDER AREA
 - 2-2.FRONT SHELL:
 - Ni 30u" MIN. UNDER PLATED OVER ALL.
 - 3.MECHANICAL PERFORMANCE,
 - 3-1.INSERTION FORCE: 0.5~2.0kgf.
 - 3-2.REMOVAL FORCE: 0.8kgf~2.0kgf.
 - 3-3.DURABILITY: 10000 CYCLES.
 - 4.ELECTRICAL PERFORMANCE,
 - 4-1. CURRENT RATING:5A
VOLTAGE RATING: 20V
 - 4-2.INSULATION RESISTANCE: 100MΩ MIN
 - 4-3.DIELECTRIC WITHSTAND VOLTAGE,AC 100V FOR 1 MINUTE.
 - 4-4.LOW CONTACT RESISTANCE: INITIAL 40MΩ
AFTER 50MΩ
 5. ENVIRONMENTAL PERFORMANCE:
 - OPERATING TEMPERATURE: -30°C~+80°C.
 - 6.IR REFLOW:
 - THE PEAK TEMPERATURE ON THE BOARD SHALL BE MAINTAINED FOR 10 SECONDS AT 260°C.
- U5 092- 16P x x 7.35L
 ↓ ↓ ↓ ↓ ↓ ↓
 名称 流水号 PIN位 N;母座 T;带弹 L;长度

DESIGN	Li Jinwei	SCALL	
DRAWING	Wu Qifa	UNIT	mm
CHECK	Zheng Jinxian	SIZE	A4: 210 * 297
APPROVAL	Liu Xiaohong	DATE	2020-06-10

⌀	
TOLERANCE	
X.X ±0.30	X.°±2°
.XX ±0.20	.X° ±1°
.XXX ±0.10	.XX°±0.5°

DRAWG NO.	U5092-16PNT7.35L
TITLE:	16P 板上四脚插板SMT 带弹带柱 7.35L

东莞市宏煜盛实业有限公司
 Dongguan hongyusheng Industry Co., Ltd
 TEL: 0769-81230179 <https://www.hystypec.com>

ROHS
Compatible

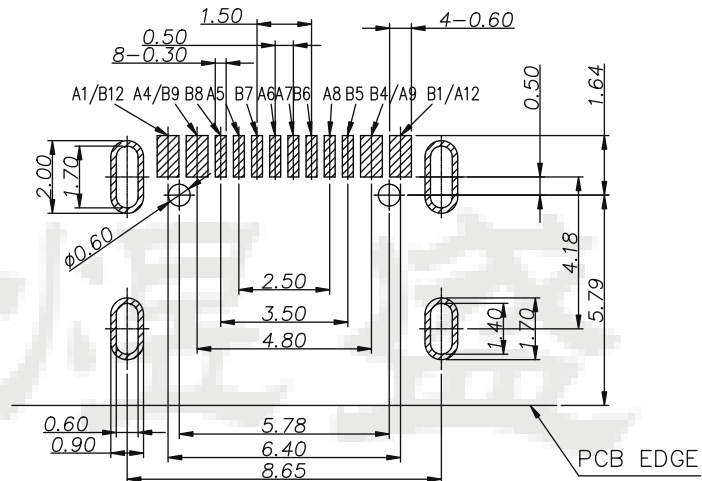
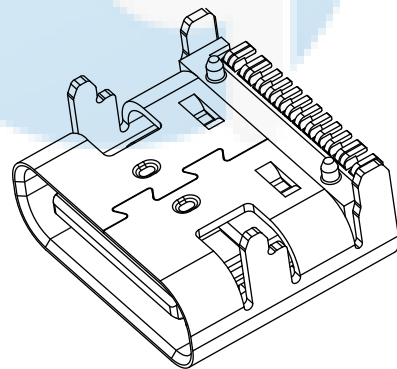
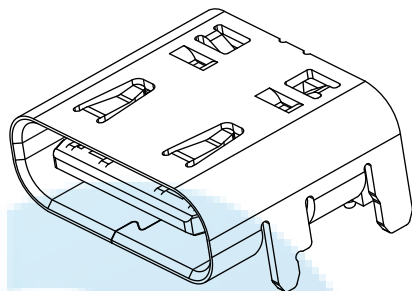

RECOMMEND P.C.B LAYOUT (COMPONENT SIDE)
TOLERANCE FOR PCB LAYOUT IS ± 0.05

USB TYPE-C PIN ASSIGNMENTS

PIN NUMBER	SIGNAL NAME	PIN NUMBER	SIGNAL NAME
A1	GND	B12	GND
A4	VBUS	B9	VBUS
A5	CC1	B8	SBU2
A6	Dp1	B7	Dn2
A7	Dn1	B6	Dp2
A8	SBU1	B5	CC2
A9	VBUS	B4	VBUS
A12	GND	B1	GND

DESIGN	Li Jinwei	SCALE		 TOLERANCE X.X ± 0.30 X. $^{\circ}$ $\pm 2^{\circ}$.XX ± 0.20 .X. $^{\circ}$ $\pm 1^{\circ}$.XXX ± 0.10 .XX. $^{\circ}$ $\pm 0.5^{\circ}$
DRAWING	Wu Qifa	UNIT	mm	
CHECK	Zheng Jinxian	SIZE	A4: 210 * 297	
APPROVAL	Liu Xiaohong	DATE	2020-06-10	

DRAWG NO. U5092-16PNT7.35L
TITLE: 16P 板上四脚插板SMT 带弹带柱 7.35L

东莞市宏煜盛实业有限公司
Dongguan hongyusheng Industry Co., Ltd
TEL: 0769-81230179 <https://www.hystypec.com>

ROHS
Compatible

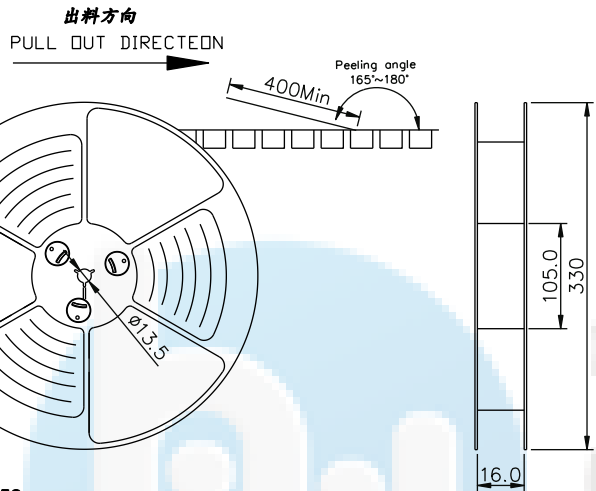

NOTES

1. 帶子引導長度
LEAD TAPE LENGTH

出料方向 PULL OUT DIRECTEON
出料方向 PULL OUT DIRECTEON

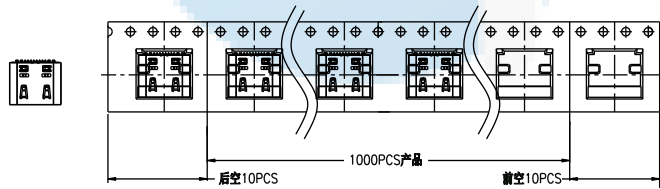

2. 上帶剝力力為: 0.1~1.3N(10.2gf~130gf)

PEELING OFF FORCE OF TOP TAPE: 0.1~1.3N(10.2gf~130gf)

出貨運輸過程中一定注意:

THIS REQUIREMENT SHOULD BE APPLIED AT SHIPMENT:

卷帶在運輸過程中不能散開

PEELING OFF SHOULD NOT BE ALLOWED DURING TRANSPORTATION

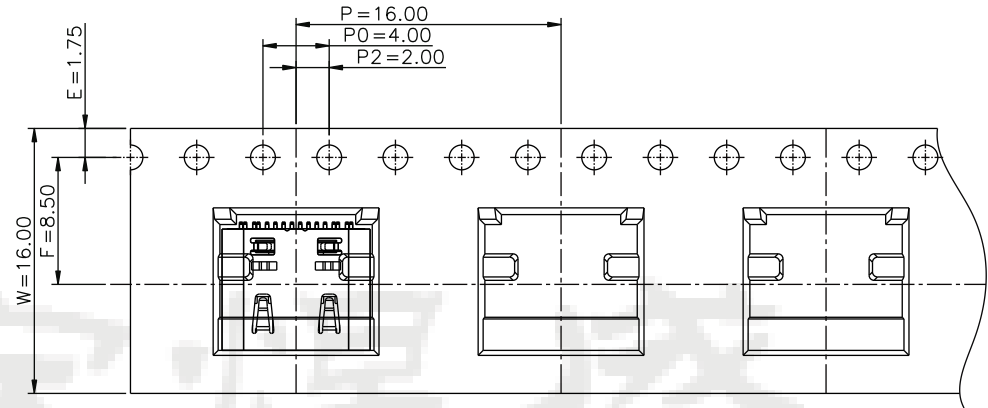

TAPE & REEL 10 PCS

1 REEL
= 1000 PCS

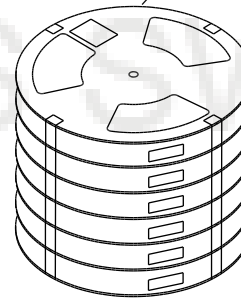

BOX

DIMENSIONS:
33. 5X33. 5X30. 5

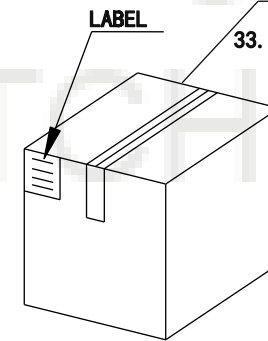

1 CARTON
=14 REELS
=14000 PCS

包裝明細表 (The detail of the packing)

產品料號 (Product No.)	包裝容量 (Packing Capacity)			重量 Weight (Kg)		
	pcs/box	boxs/Carton	Pcs/Box	N.W./Pcs	N.W./Box	G.W./Box
U5092-16PNT7.35L	1000	14	14000	---	---	---

DESIGN	Li Jinwei	SCALL		 TOLERANCE X.X ±0.30 X.°±2° .XX ±0.20 .X°±1° .XXX ±0.10 .XX°±0.5°
DRAWING	Wu Qifa	UNIT	mm	
CHECK	Zheng Jinxian	SIZE	A4: 210 * 297	
APPROVAL	Liu Xiaohong	DATE	2020-06-10	

DRAWG NO.	U5092-16PNT7.35L
TITLE:	16P 板上四脚插板SMT 帶彈帶柱 7.35L



东莞市宏煜盛实业有限公司
Dongguan hongyusheng Industry Co., Ltd
TEL: 0769-81230179 <https://www.hystypec.com>