

ROHS
Compatible

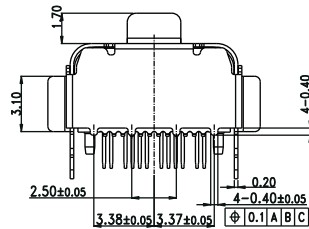

NOTES:

- 1.MATERIAL :SEE TABLE
- 2.COPLANARITY : 0.10 Max.
- 3.ELECTRICAL CHARACTERISTICS
LOW LEVEL CONTACT RESISTANCE: 40mΩ Max
INSULATION RESISTANCE:100MΩ MIN
DIELECTRIC WITHSTANDING VOLTAGE:100 VAC:
CONTACT CURRENT RATING:5A Max
- 4.MECHANICAL CHARACTERISTICS
INSERTION FORCE: 5~20N
EXTRACTION FORCE: 8~20N
AFTER DURABILITY EXTRACTION FORCE: 6~20N
- 5.DURABILITY: 10000 CYCLES
- 6.PACKAGING TYPE: CARRIER TAPE.
- 7.SALT SPRAY : 24 HOURS

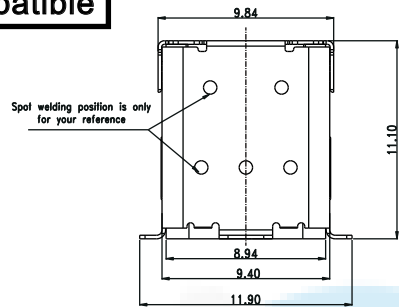
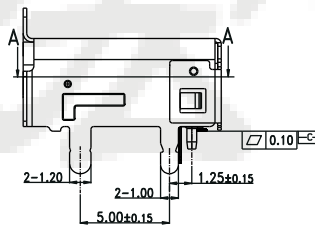
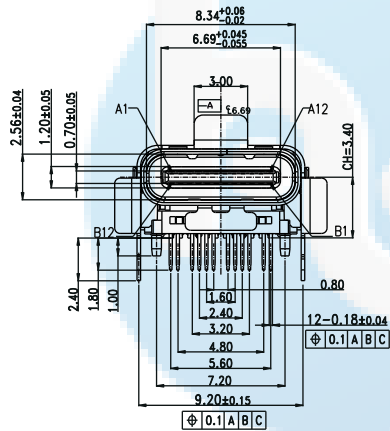

U5 411- 24P x 3.4H 11.1L
↓ ↓ ↓ ↓ ↓ ↓
名称 流水号 PIN位 N;母座 H;CH L;长度

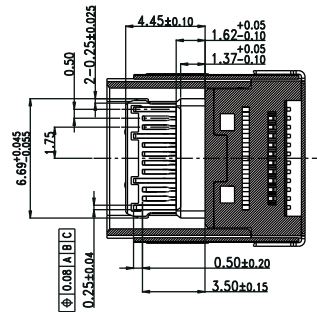
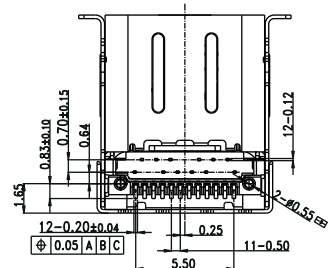

SECTION A-A

6	OUTER-SHELL	1	STAINLESS STEEL	SOLDER NICKEL: 50U" MIN
5	INNER-SHELL	1	STAINLESS STEEL	SOLDER NICKEL: 50U" MIN
4	TOP TERMINAL	1	COPPER ALLOY	MATING AREA:AU 3u" SOLDER TAIL:MATTE TIN 50 MIN, 50u" NICKEL OVERALL.
3	BOTTOM TERMINAL	1	COPPER ALLOY	MATING AREA:AU 3u" SOLDER TAIL:MATTE TIN 50 MIN, 50u" NICKEL OVERALL.
2	MID PLATE	1	STAINLESS STEEL	SOLDER NICKEL: 50U" MIN
1	MAIN HOUSING	1	HIGH TEMPERATURE BLACK	
ITEM	DESCRIPTION	Q'TY	MATERIAL	FINISH

BILL OF MATERIAL

DESIGN	Li Jinwei	SC ALL		 TOLERANCE X.X ±0.30 X.°±2° .XX ±0.20 .X°±1° .XXX ±0.10 .XX°±0.5°	DRAWG NO.	U5411-24PN3.4H11.1L
DRAWING	Wu Qifa	UNIT	mm		TITLE:	24P 板上四脚插板DIP+SMT 后盖带四点 CH3.4 带翻边 11.1L
CHECK	Zheng Jinxian	SIZE	A4: 210 * 297			
APPROVAL	Liu Xiaohong	DATE	2020-06-10			



东莞市宏煜盛实业有限公司
Dongguan hongyusheng Industry Co., Ltd
TEL: 0769-81230179 <https://www.hystypec.com>

ROHS
Compatible

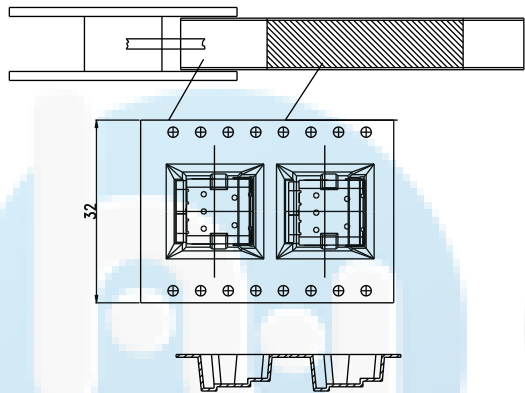

Pick and place

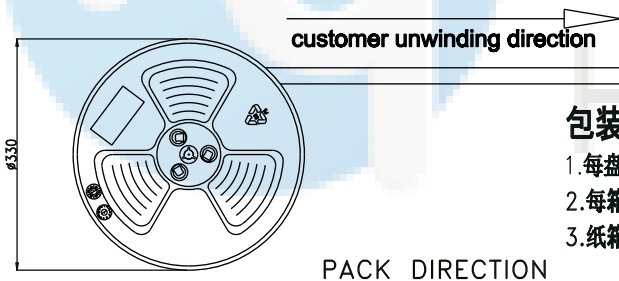
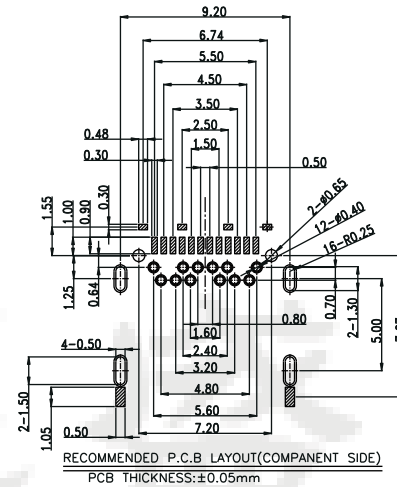

包装明细:

1. 每盘装数300PCS
2. 每箱10盘, 共计3000PCS
3. 纸箱尺寸: 34X34X38CM

Pin No	Signal Name	Mating Sequence	Pin No	Signal Name	Mating Sequence
A1	GND	First	B12	GND	First
A2	TX1+	Second	B11	RX1+	Second
A3	TX1-	Second	B10	RX1-	Second
A4	Vbus	First	B9	Vbus	First
A5	CC1	Second	B8	SBU2	Second
A6	D+	Second	B7	D-	Second
A7	D-	Second	B6	D+	Second
A8	SBU1	Second	B5	CC2	Second
A9	Vbus	First	B4	Vbus	First
A10	RX2-	Second	B3	TX2-	Second
A11	RX2+	Second	B2	TX2+	Second
A12	GND	First	B1	GND	First
SHELL	GND		SHELL	GND	

DESIGN	Li Jinwei	SC ALL		 TOLERANCE X.X ±0.30 X.°±2° .XX ±0.20 .X°±1° .XXX ±0.10 .XX°±0.5°	DRAWG NO.	U5411-24PN3.4H11.1L
DRAWING	Wu Qifa	UNIT	mm		TITLE:	
CHECK	Zheng Jinxian	SIZE	A4: 210 * 297			
APPROVAL	Liu Xiaohong	DATE	2020-06-10			24P 板上四脚插板DIP+SMT 后盖带四点 CH3.4 带翻边 11.1L

东莞市宏煜盛实业有限公司
Dongguan hongyusheng Industry Co., Ltd
TEL: 0769-81230179 <https://www.hystypec.com>